

T8 26 mm

Electronic ballast Linear lamps T8, 26 mm

PC 4x36 GM 001 220-240 V 50/60/0 Hz, non dimmable

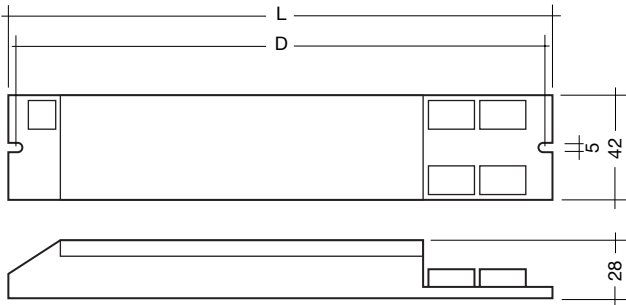

- Defined warm start within 2 s
- Constant light output from 198 V – 254 V supply voltage
- AC operation 198 V – 254 V
- DC operation 176 V – 254 V DC (lamp start 198 V – 254 V DC)
- Power factor 0.98
- Overvoltage protection 320 V AC, 1 h
- Operating frequency ≥ 30 kHz
- Wide temperature range from -25°C to $+50^{\circ}\text{C}$

- Energy classification EEL = A3
- ENEC approved, CE marked
- Use in emergency lighting according to VDE 0108 possible
- Automatic restart after lamp change by removing/replacing the lamp designated for emergency operation
- Safe switch off of defective lamps
- Automatic end of lamp life shut off
- Temperature protection ∇ acc. to EN 60928-B.5e

Approvals:

- EN 60928
- EN 60929
- EN 61000-3-2
- EN 61547
- EN 55015
- acc. VDE 0108
- IEC 68-2-64 Fh
- IEC 68-2-29 Eb
- IEC 68-2-30

Lamp		Ballast											
wattage W	length mm	type	article number	length L mm	fixing centres D mm	weight g	circuit power W	lamp power W	current at 230V/50Hz A	λ at 230V/50Hz	tc point $^{\circ}\text{C}$	temperature range $^{\circ}\text{C}$	
36	1200	PC 4x36 GM 001	220-240 V 50/60/0 Hz	89818848	424	414	379	142	132	0.63	0.98	75	-25 \rightarrow +50

Installation instructions

Wiring type and cross section

The wiring can be in flexible cable with ferules or solid with a cross section of 0.5 – 1.5 mm².

Strip 9 mm of insulation from the cables to ensure perfect operation of the screwless terminals.

wire preparation:
0.5 – 1.5 □

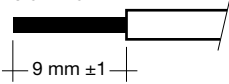

RFI

Tridonic ballasts are RFI protected in accordance with EN 55015. To operate the luminaire correctly and to minimise RFI we recommend the following instructions:

- Connection to the lamps of the hot leads must be kept as short as possible
- Mains leads should be kept apart from lamp leads (ideally 5 – 10 cm distance)
- Do not lead mains leads too closely along the electronic ballast
- Twist the lamp leads
- Keep the distance of lamp leads from the metal work as large as possible
- Mount electronic ballast on earthed metal surface
- Mains wiring to be twisted when through wiring
- Keep the mains leads inside the luminaire as short as possible

AC operation

Mains voltage:
220 – 240 V 50/60 Hz (-10% / +6%)

DC operation

220 – 240 V DC
198 – 254 V DC certain lamp start
176 – 254 V DC operating range

Emergency lighting

Use in emergency lighting installations according to VDE 0108.
BLF > 0.95 at 220 V DC
Four pole emergency lighting modules should be used.

Ingress protection

IP 20

Packing quantities

10 pieces/carton
48 cartons/pallet
480 pieces/pallet

Wiring advice

The lead length is dependent on the capacitance of the cable.

Ballast Type	Terminal		Maximum capacitance allowed	
	Cold	Hot	Cold	Hot
PC 4x36 GM 001	7, 8, 9, 10	1, 2, 15, 16	200 pF	100 pF

With standard solid wire 0.5/0.75 mm² the capacitance of the lead is 30 – 80 pF/m.

This value is influenced by the way the wiring is made.

Lamp connection should be made with symmetrical wiring.

Hot leads (1, 2, 15, 16) and cold leads (7, 8, 9, 10) should be separated as much as possible.

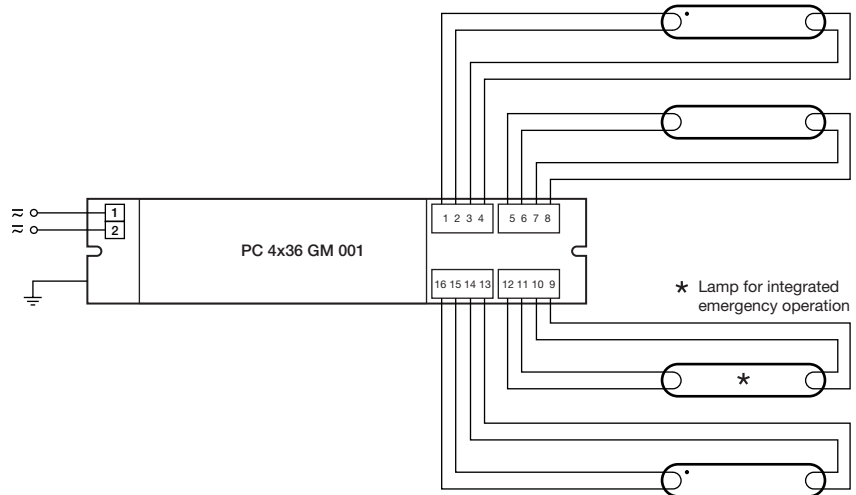

Circuit diagram PC 4x36 GM 001

Harmonic distortion in the mains supply

Ballast Type	THD	3	5	7	9
PC 4x36 GM 001	9 %	7 %	3 %	1 %	2 %

Typical value expressed as a percentage at 230 V 50 Hz

Temperature range

from -25 °C to +50 °C

